

## SPARES PARTS REPLACEMENT HYDRAULIC ACTUATORS

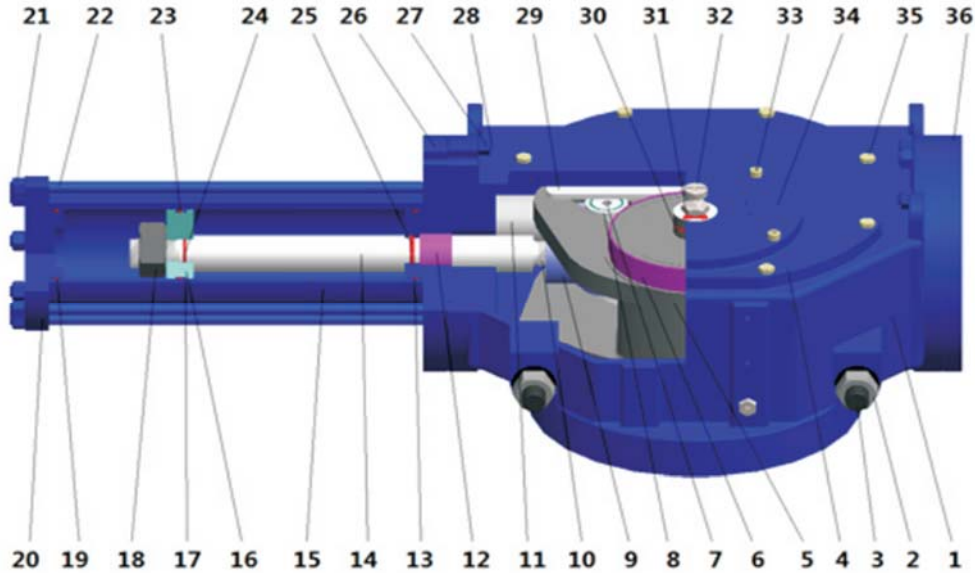

Spares of SY02 F30-90DA :

**NO.13:** Oring dimension 55\*45\*6.5 (Hydraulic module to center body)

**NO.25:** oring dimension 90\*5.7 (center bar, center body)

**NO.24:** Oring dimension 45\*3.5 (Center bar, piston)

**NO.23:** Oring dimension 90\*75\*10 (2 PCS) (piston)

**NO.19:** Oring dimension 90\*5.7 (Hydraulic module to end cap)

Spares of SY02 F10-40DA :

**NO.13:** Oring dimension 35\*25\*6.5 (Hydraulic module to center body)

**NO.25:** Oring dimension 45\*3.5 (center bar, center body)

**NO.24:** Oring dimension 25\*3.1 (Center bar, piston)

**NO.23:** Oring dimension 45\*35\*6.5 (2 PCS) (piston)

**NO.19:** Oring dimension 45\*3.5 (Hydraulic module to end cap)



**Storage instructions:**

As rubber seals age the physical properties change and can cause the seals to be unusable. These changes are caused by many factors such as light, ozone, humidity, etc. These factors can cause the rubber to harden, soften, crack or cause other surface degradations. Proper storage is needed to reduce the effects these factors have on the rubber.

Proper storage is essential in extending the shelf life of O-rings. Rubber seals and molded rubber products, whether in bulk or in assemblies, should be placed in sealed bags and kept in boxes out of sunlight and excessive temperatures and humidity. Temperatures should be higher than 59°F and below 100°F. 68°F-70°F is optimal with the humidity no greater than 75%, 65%.

When O-rings are exposed to extreme cold below their normal operating range they can harden and their shape can become distorted. The effects of extreme cold are not damaging to most elastomeric seals and they usually return to their normal when they warm up. Exposure to excessive heat can accelerate the deterioration of the rubber. The effects caused by excessive heat usually are not reversible. ARP5316, Recommended Shelf Life is 5 years after purchase order date under



RESEARCH & DEVELOPMENT

**ACTREG S.A.U.**  
Carrer de la Ciència, 45-47  
08840 VILADECANS - Barcelona (Spain)  
Tel. + (34) 93 661 44 10 - Fax + (34) 93 654 33 93  
sales@actreg.com - www.actreg.com

**Registered Office:**  
Av. Segle XXI, 75 - Pol. Ind. Can Calderon  
08830 Sant Boi del Llobregat - Barcelona (Spain)